

Littfinski DatenTechnik (LDT)

Kleiner Ring 9 • D-25492 Heist/Germany • Phone: 0049 4122 / 977 381 • Fax: 0049 4122 / 977 382



# Operation Instruction

# TurnTable-Decoder

# TT-DEC

from the *Digital-Professional-Series* !

TT-DEC-G Part-No.: 010503

>> finished module in a case <<

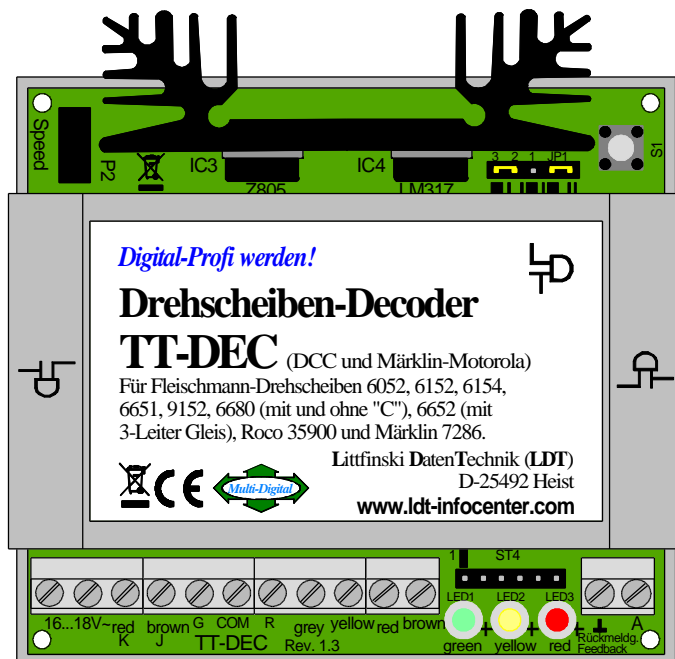

Suitable for Fleischmann turntables 6052, 6152, 6154, 6651, 9152, 6680 (each with and without "C") and 6652 (with 3-rail conductor), the Roco turntable 35900, as well as for the Märklin turntable 7286.

For the data formats Märklin Motorola and DCC.

Compatible commands for the Märklin turntable electronic 7686.

This product is not a toy! Not suitable for children under 14 years of age! The kit contains small parts, which should be kept away from children under 3! Improper use will imply danger of injuring due to sharp edges and tips! Please store this instruction carefully.

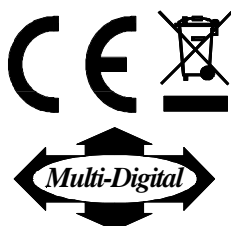



# TT-DEC – Manual

<b>Content:</b>	<b>Page</b>
<b>1. Preface / Safety Instruction</b>	<b>1</b>
<b>2. Selecting the available turntable</b>	<b>2</b>
<b>3. Connecting the TT-DEC to the digital layout and to the turntable</b>	<b>3</b>
<b>4. Programming the TurnTable-Decoder TT-DEC</b>	<b>6</b>
<b>4.1. Programming of the basic address and data format</b>	<b>6</b>
<b>4.2. Adjusting the turntable bridge speed and the cycle frequency</b>	<b>8</b>
<b>4.3. Programming track connections</b>	<b>9</b>
<b>4.4. Change the bridge track polarity on Fleischmann and Roco turntables</b>	<b>11</b>
<b>4.5. Synchronizing the reference track</b>	<b>13</b>
<b>4.6. Special function: Turntable test / Factory setting</b>	<b>13</b>
<b>4.7. Programming- and Control-table</b>	<b>14</b>
<b>5. Feedback reports</b>	<b>15</b>
<b>6. Assembly plan</b>	<b>19</b>

## **1. Preface / Safety Instruction:**

You have purchased the **TurnTable-Decoder TT-DEC** for your model railway layout supplied within the assortment of **Littfinski DatenTechnik (LDT)**.

We are wishing you having a good time for the application of this product!

The purchased unit comes with a **24 month warranty** (validity for the finished module in a case only).

- Please read this **instruction careful**. For **damages** caused by **disregarding** this **instruction** the right of **claiming guarantee** will **expire**. **No liability** will be taken over for **resultant damages**. You can download **this manual as a PDF-file** with **colored pictures** from the area **“Downloads”** at **our Web-Site**. The file can be opened with the **Acrobat Reader**.
- **Attention:** Carry out any connections only with **disconnected** model railway layout (switch-off the transformers or disconnect the main plug).

# TT-DEC – Manual

## 2. Selecting the available turntable:

The TurnTable-Decoder TT-DEC is suitable for the application on **Fleischmann turntables 6052, 6152, 6154, 6651, 9152, 6680** (each with and without “C”) and **6652** (with 3-rail conductor), the **Roco turntable 35900**, as well as on the **Märklin turntable 7286**.

On the right side between the housing-cover and the heat-sink of the TT-DEC is a **5-pole pin bar** located marked with **JP1**. Please take-off the housing cover for performing the following adjustments.

**Ex-factory** will be **two jumpers** inserted at this pin bar. One jumper at the left and one jumper right. The middle pin will be vacant. The draft **2.3.** shows the adjustment for the **Fleischmann turntable 6154, 6680 or 6680C** and the **Roco turntable 35900** for the **gauge TT** with **24 possible track connections**.

If you use a **Fleischmann turntable** for **gauge N** or **H0** with **48 track connections** (**6052, 6152, 6651, 6652** und **9152** – each with and without “C”) please insert a **jumper** as shown below under **2.2.**

If you want to use the **TurnTable-Decoder TT-DEC** together with the **Märklin turntable 7286** please insert a **jumper** as described under **2.1.**

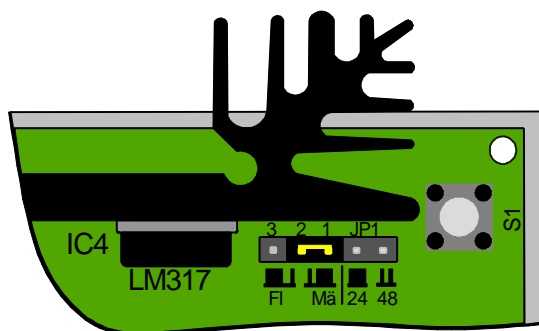

### 2.1. Märklin turntable 7286:

A jumper has to be set onto the pins marked with 1 and 2.

The second jumper supplied together with the set will not be required.

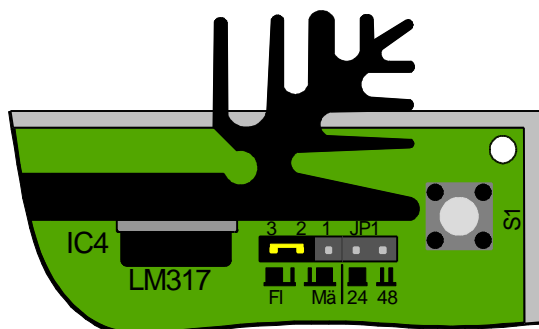

### 2.2. Fleischmann turntable for gauge N or H0 with 48 track connections:

A jumper has to be set onto the pins marked with 2 and 3.

The second jumper supplied together with the set will not be required.

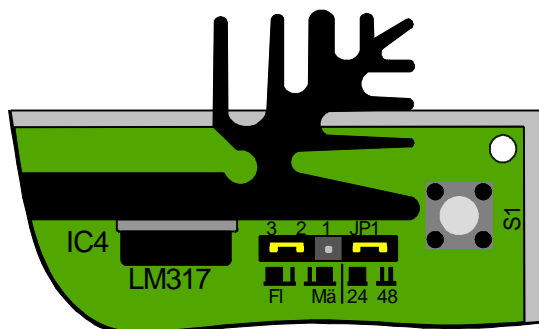

### 2.3. Fleischmann turntable 6154, 6680 or 6680C and Roco turntable 35900 (gauge TT) with 24 track connections:

One jumper has to be set onto the pins marked 2 and 3 at the left side and the second jumper has been set to the right side marked with JP1 (**factory setting**).

# TT-DEC – Manual

## 3. Connecting the TT-DEC to the digital layout and to the turntable:

- **Important Information:** Switch-off the electrical supply before performing any connection work (switch-off all transformers or un-plug the main plug).

### 3.1. Connecting the TT-DEC to the digital layout:

The TurnTable-Decoder TT-DEC receives the **power supply** via the **two clamps** at the **very left side of the 11-poles connection clamp**. The voltage can be between **16 and 18 Volt~** (alternated voltage of a model railway transformer). Both clamps are marked accordingly.

The decoder receives the **digital information** via the **third and fourth clamp (counted from the left side)** of the **11-poles connection clamp**. Supply the digital information directly from the **control-unit** or from a **booster** respectively from the **digital ring conductor “switching”** which has been connected to all accessory decoders. To assure that the **TT-DEC** receives **interference-free data** do not take the digital information directly from the rails.

One of the two digital clamps has been marked with **red** and **K** and the other has been marked with **brown** and **J**. The colors **red** and **brown** respectively the marking **J** and **K** will be used by most command stations.

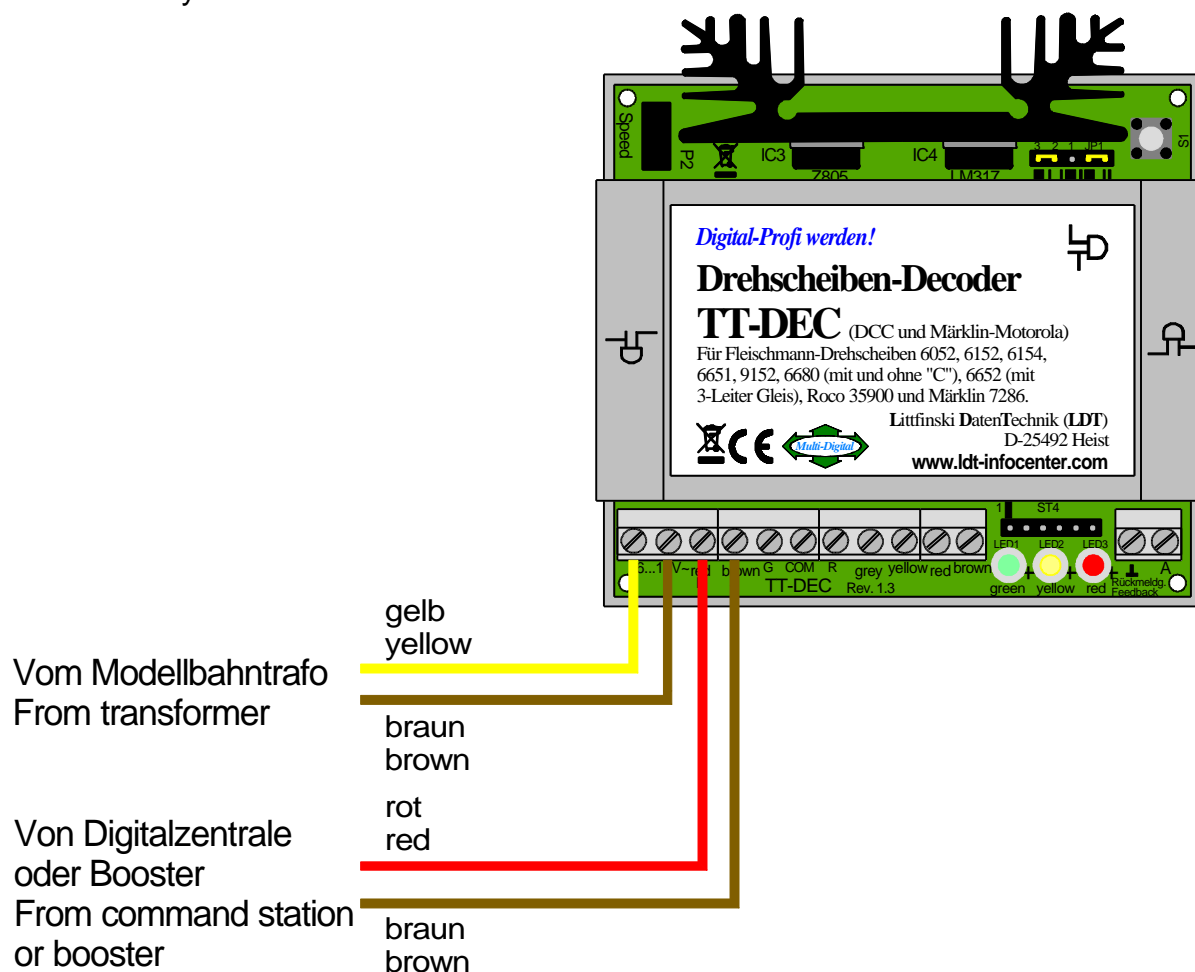

## TT-DEC – Manual

### 3.2. Connecting the TT-DEC to a Fleischmann turntable 6052, 6152, 6154, 6651, 6652, 9152 or 6680 (each with and without “C”) and Roco turntable 35900:

All **Fleischmann turntables** and the **Roco turntable 35900** contain a **5-poles flat ribbon cable**. The **two yellow wires** on the **right side** are for the **supply to both bridge rails**. For a simple connection this wires can be connected to the **digital ring conductor “drive”**.

If you want to **change the polarity** of the **bridge rails automatically** via the **TurnTable-Decoder TT-DEC** (problems of the reverse loop by bridge turning of 180°) the two wires have to get the digital current supply from a **permanent power switch unit DSU (DauerStromUmschalter)**. Additional information is available within the chapter **“Change the bridge track polarity on Fleischmann turntables”**.

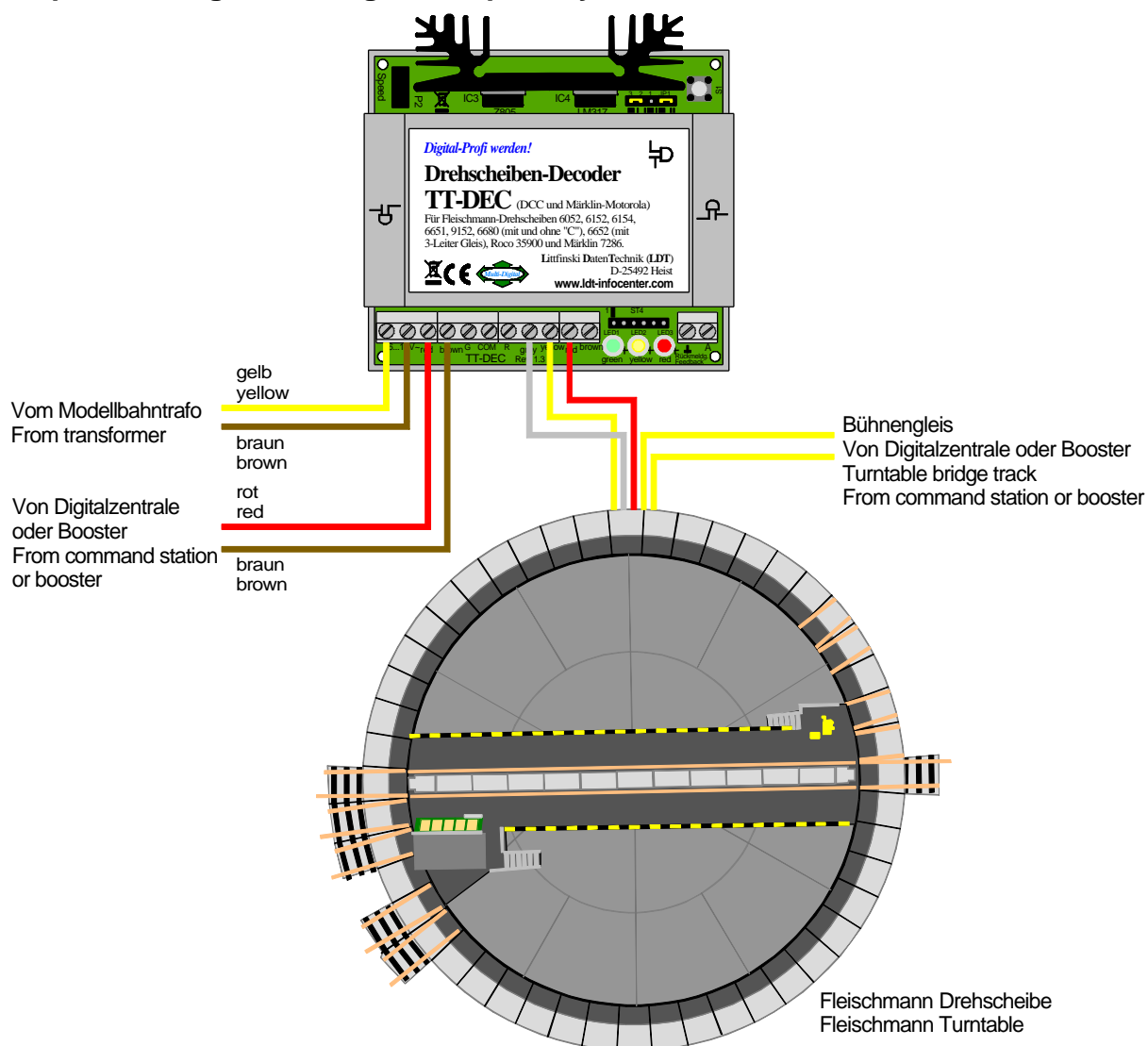

The **red, gray and yellow** wire of the **5-poles flat ribbon cable** has to be connected to the clamps **“red”, “gray” and “yellow”** of the TT-DEC as indicated within the sketch.

The **manual turntable switch**, supplied together with the Fleischmann turntable, **shall not be connected in this case**.

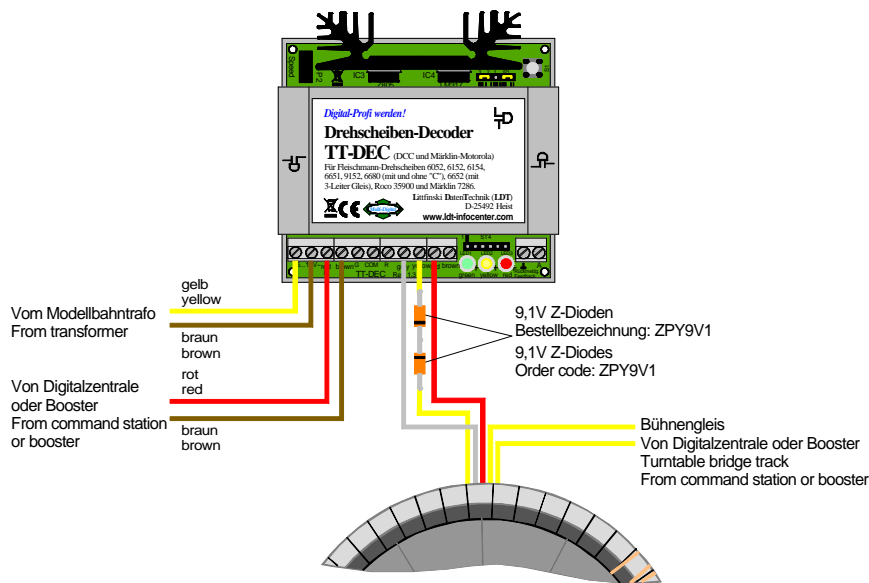

If you use a Fleischmann turntable equipped with a motor from sb modellbau you have to connect the TurnTable-Decoder TT-DEC with the yellow cable by using two diodes. The suitable sample connection 527 can be found on our Web-Site at the section "Sample Connections".

### 3.3. Connecting the TT-DEC to the Märklin turntable 7286:

The Märklin turntable 7286 contains a 6-poles flat ribbon cable incl. plug.

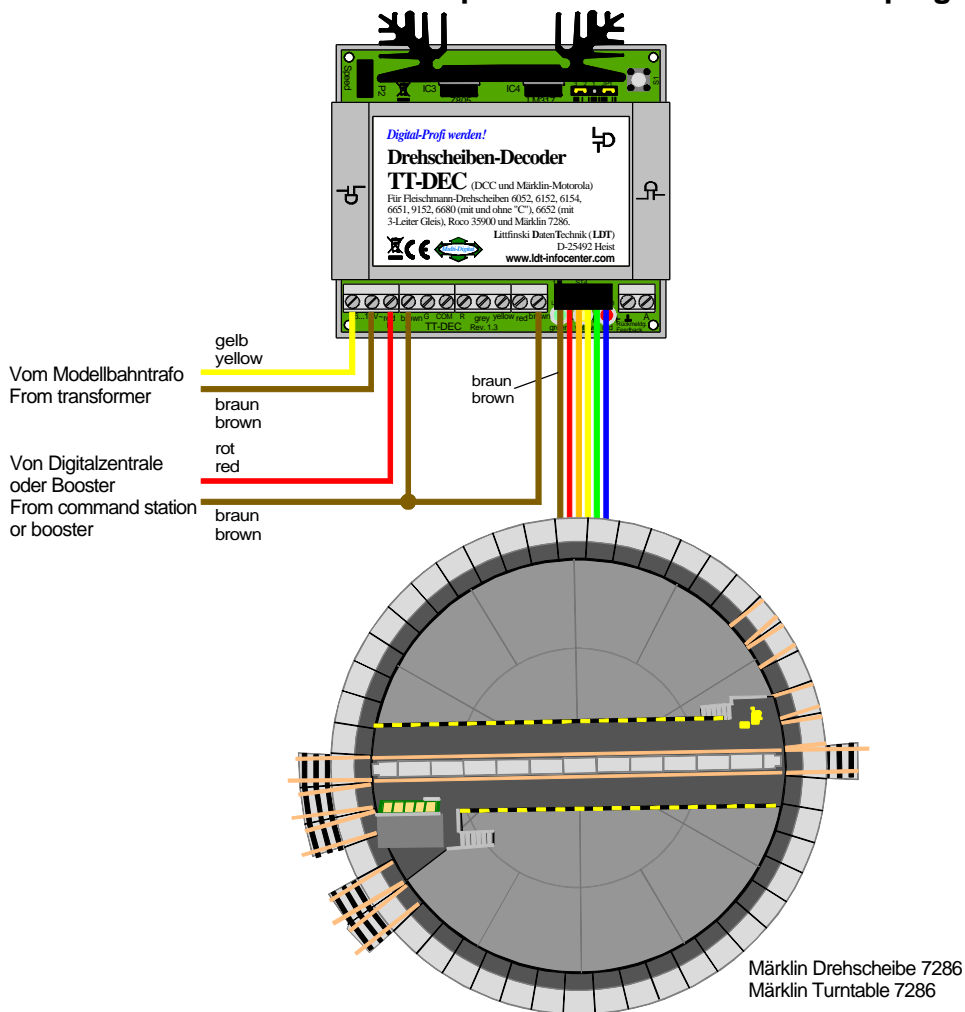

## TT-DEC – Manual

The direction to connect the plug to the **6-poles pin bar** of the **TT-DEC** has to assure that the **flat ribbon cable** shows **away from the decoder**. The cable should not be twined around the plug. The connection to the turntable is correct if the **brown single wire of the flat ribbon cable shows in direction to the 11-poles clamp bar**.

The **manual turntable switch**, supplied together with the Märklin turntable, **shall not be connected in this case**.

For an installation of the decoder at a **larger distance** to the turntable you can use our **extension cable “Kabel s88 0,5m”, “Kabel s88 1m” or “Kabel s88 2m”** with a length of 0,5 meter, 1 meter respectively 2 meter. For a correct installation of the extension you can download the **sample connection 502** from our Web-Site.

Additionally connect the digital cable **“brown”** to the **very right clamp** of the **11-poles clamp bar** which is marked with **“brown”**. This is the supply for the **second outer rail** of the turntable. This rail can be as well used as contact rail for an occupation report. You can find more details within the **section “Feedback Reports”**.

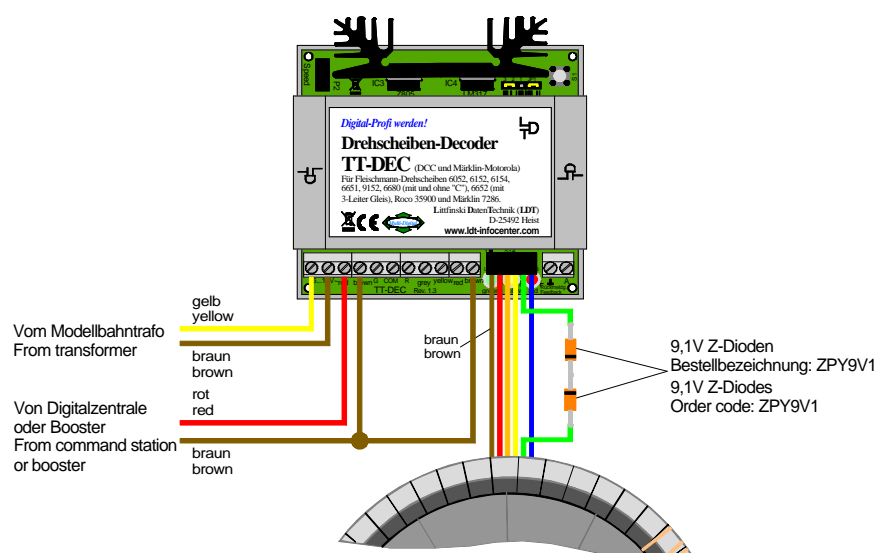

If you use a Märklin turntable equipped with a **motor from sb modellbau** you have to connect the **TurnTable-Decoder TT-DEC** with the **green cable** by using **two diodes**. A suitable **sample connection 528** can be found on our **Web-Site** at the section **“Sample Connections”**.

### 4. Programming the TurnTable-Decoder TT-DEC:

For the first start please take care that you follow exact the sequences of the programming as described below.

#### 4.1. Programming of the basic address and the data format:

The **TurnTable-Decoder TT-DEC** will be controlled by **accessory addresses (turnout addresses)** which will be used as well **for switching of turnouts or signals**.



## TT-DEC – Manual

The command structure of the **TT-DEC** is **compatible to the commands** of the **Märklin turntable-decoder 7686**. It does not matter if you actual want to digital control a **Märklin-** or a **Fleischmann turntable**.

The indication of the **data format** for the control of the **TurnTable-Decoder TT-DEC** from the command station (**Märklin-Motorola** or **DCC**) is not required. The data format will be automatically recognized from the **TT-DEC** during the following **programming process** of the **basic address**.

With reference to the **Märklin turntable decoder 7686** is the **TurnTable-Decoder TT-DEC** able to use **two address sections**. If you use a **PC-model railway software** for the control of the turntable you find mostly for the **two address sections** the **indication of 14 and 15**. With this selection is it possible to operate **2 turntables** via **2 TurnTable-Decoders TT-DEC** on your layout.

The **address section 14** covers the **addresses 209 till 224** and the **section 15** covers the **addresses 225 till 240**. Only by using the **full capacity** of the turntable with **48 track connections** all addresses within the selected address section will be required. If you use a **multi protocol command station** which is able to send several data formats you have to take care that **all addresses** within the **selected address section** will be adjusted uniform to **Märklin-Motorola** or **DCC**.

A **table** showing the **coherence** between **address section, address and turntable-function** can be found at **chapter 4.7. "Programming- and Control-Table"** within this operation instruction. This table gives you as well the information about the **symbols** (if required) your **model railway software** uses for the various **turntable functions**.

### Programming process:

1. **Switch-on** your **digital-layout and the TurnTable-Decoder TT-DEC**. If you want to perform the programming of the **TT-DEC** via your **model railway software** you have to **switch-on those** and **adjust the turntable** if required at first **in accordance** to the **relevant instruction** of the **software**. It is important that your **model railway software supports** the **Märklin-turntable decoder 7686** because the **TT-DEC** is **compatible to the commands** of the **Märklin decoder**.
2. Please **press shortly 1-times** the **key S1** which is located at the **right side** next to the **TT-DEC heat-sink**. Now the **yellow LED** will **flash**.
3. **Send now several times** the command **>Drehrichtung<** (**Turning Direction**) at **clockwise direction** or **anti clockwise** from your **command station** or from your **model railway software** in accordance to the **programming- and control table** (**chapter 4.7.**). If the **TT-DEC** has **recognized the command** after **several sending intervals** this will be indicated by a **switched-off yellow LED**.
4. The **TT-DEC** will leave the **programming mode** automatically. All **three light emitting diodes** will **glow**.



## 4.2. Adjusting the turntable bridge-speed and the cycle-frequency:

Because every turntable contains **different mechanical and electrical characteristics** is it required to adjust a **safe and realistic operation** via the **TurnTable-Decoder TT-DEC** with **two potentiometers**.

The **factory setting** of both **potentiometers** is in **middle position**. The **potentiometer P1** for **cycle frequency** (illustration 1) can be adjusted from the **right side** after **detaching the housing cover**. The **potentiometer P2** for the **turntable speed** (illustration 2) is located at the **rear left side next to the heat sink**.

Illustration 1: Potentiometer P1 “Cycle frequency”.

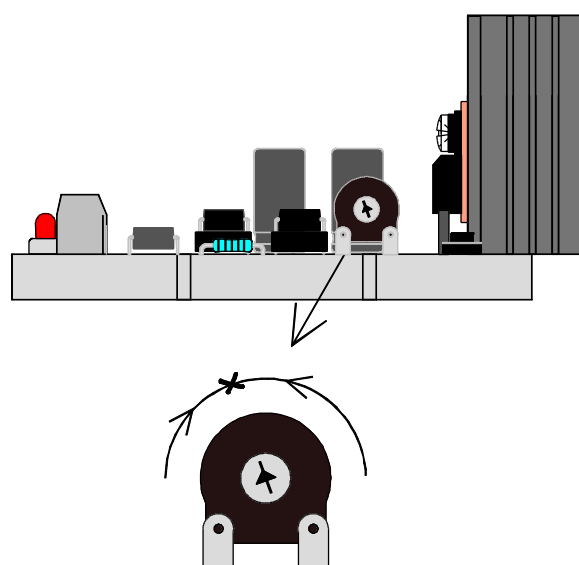
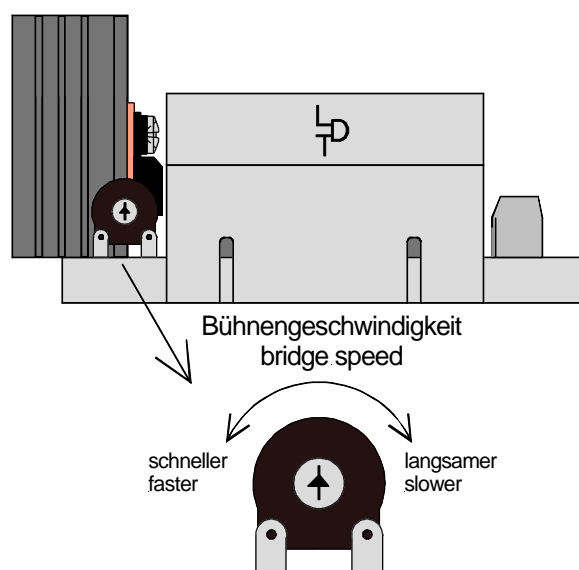

Illustration 2: Potentiometer P2 “Turntable bridge speed”.



### Adjustment:

1. Set **both potentiometers** into **middle position** by using a **small suitable screw driver** (**factory setting** because **this position** covers the requirement of **most turntables**).
2. For a **180 degree turning** of the **turntable bridge send** now the command **>turn<** from your **command station** or from your **model railway software** in accordance with the **programming- and control table** (**chapter 4.7**).
3. Each **track connection** should initiate a **clicking noise**.
4. If you hear **no regular clicking** for each **track connection** in both turning directions send several **>turn<** commands and **turn the potentiometer P1 “cycle frequency”** from the middle position **slowly to the right side** until the **clicking noise** on each track connection will **fall completely silent** and the **turntable bridge will stop**. **Repeat** the adjustment and **turn the potentiometer slowly to the left** until the **clicking noise** will fall again **completely silent**. The **optimal position** of the **potentiometer P1 “cycle frequency”** will be between the two positions where the clicking noise will fall silent. Illustration 1 shows the coherence.



## TT-DEC – Manual

5. With the **potentiometer P2** “**turntable bridge speed**” is it possible to **change the turning speed of the bridge**. The **clicking of each track connection** shall be audible. **Change the turning direction** of the bridge with the command **>Drehrichtung<** (**turning direction**) and correct the **turning speed** with the **potentiometer P2**.
6. **Control:** After further **>turn<** commands in **both directions with and without locomotive** the **turntable bridge** should **turn each time by 180 degree** to the same track connection. **If necessary repeat the adjustment** as described under **1 to 5** with a **little higher turning speed**. If the **turning bridge** is turning **generally unevenly** please **check the mechanical components** of your **turntable**.

### 4.3. Programming track connections:

#### Please attend:

The **adjustment of the turntable bridge speed and the cycle frequency** has to be completed in accordance to **section 4.2** to assure a turning of the turntable bridge by **180 degree** by each **>Turn<** command before **starting** with the **programming of the track connections**.

By **programming the track connections** you should prepare your **TurnTable-Decoder TT-DEC** to be able to **recognize all available track connections** and **turn the turntable bridge** to the **required track connection during the operation**. During the **programming process** please **define one track connection as track 1** as a so-called **reference track**.

#### Programming process:

1. **Press shortly the key S1 2 times**. The **green LED flashes**.
2. **Send now the command >Input<**. The **red LED will be shortly switched-off** and the **turntable bridge** turns eventually to the last programmed reference track.
3. **Turn now the turntable bridge** with the commands **>Step<** (clockwise or anti clockwise) to the **track 1 (reference track)**.
4. **Send now in accordance to the operation instruction of your command station or your model railway software** the command **>Clear<** or **>Clear<** and **>Input<** to store the position **track 1 (reference track)**. The **red LED will be switched-off shortly**.
5. **Turn the turntable bridge** with the command **>Step<** **clockwise** to the **next required track connection**. Please consider eventually as well **single opposite track connections**.
6. **Store the track connection** with the command **>input<**. The **red LED will be switched-off shortly**.
7. **Prepare further track connections on the same way**.
8. If you have **completed the programming of all track connections** send the command **>End<**. The **turntable bridge will turn to track 1 (reference track)** and the **programming mode** will be **automatically finalized**. If the **turntable bridge** will not return to the defined reference track you have to repeat the programming process.

## TT-DEC – Manual

### Programming Sample

According to the **programming sequence item 3** the turntable has been **turned** into the **reference position**. The bridge will be situated in level with the little housing on the left side.

With the command **>Clear<** or **>Clear<** and **>Input<** the position of **track 1 (reference track)** will be stored (**programming sequence item 4**).

With the command **>Step< clockwise** the bridge will turn to the next **available track connection**. This will be a **single opposite track connection (track 2)**. With the command **>Input<** will be the **track connection 2 stored**. (**programming sequence item 5 and 6**).

With the command **>Step< clockwise** it will go-on to the **track connections 3, 4, 5 and 6**. **Each track connection** will be stored via the command **>Input<**.

The **track connection 6** is the **last track connection** to be **programmed** because this is the last track connection before the bridge will stay at the **next >Step< clockwise** again on the **reference track**, but **turned by 180 degree (the little house will be then be located on the right side)**.

Therefore shall be **additionally** the command **>End<** transmitted at the **track connection 6**. The **turntable will turn to the track 1 (reference track)** and the **programming mode will be left automatically (programming sequence item 8)**.

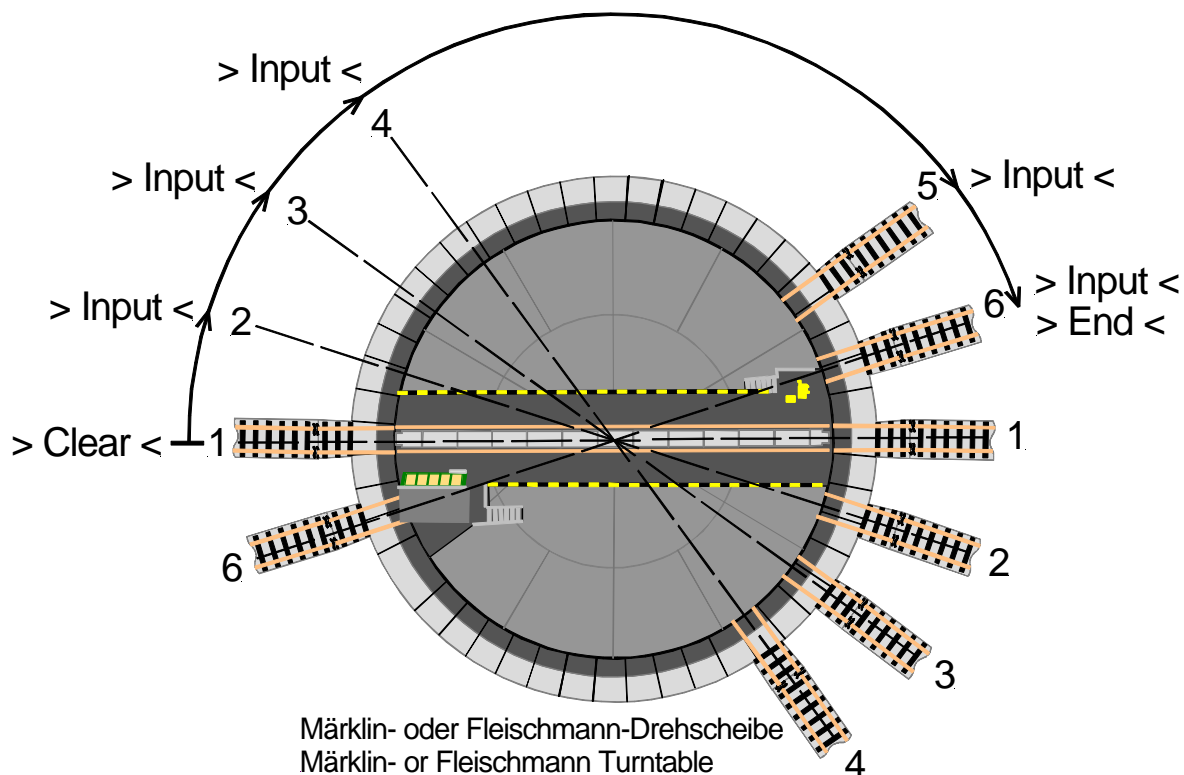

# TT-DEC – Manual

## 4.4. Change the bridge track polarity on Fleischmann and Roco turntables:

If **Fleischmann** or the **Roco turntables 35900** will be used on a digital layout with **2-conductor track** the **four track contacts of the bridge**, which connect electrically the bridge track with the track, shall be **removed**.

**Alternatively** is it possible to **isolate each rail on both sides** behind the track connections.

If the bridge track has been **electrically separated** from the **track connections** by using one of the above methods is the **constant supply with digital current of all tracks** to the turntable possible. A constant supply of the tracks with digital current can be recommended because on this way is it possible to switch **specific loc-functions on or off** even inside the locomotive shed.

But if the **turntable bridge turns by 180 degree** there will be a **short circuit** in case the polarity of the **bridge track** will not be **adapted** to the **polarity** of the contacted **track connections**.

The **TurnTable-Decoder TT-DEC** is able to **change the polarity** of the **bridge rail**. For this purpose will be the TurnTable-Decoder combined with a permanent power switch unit (**DauerStromUmschalter**) **DSU**.

The **permanent power switch unit DSU** has to be connected with the clamps **“G”**, **“COM”** and **“R”** to the **TurnTable-Decoder TT-DEC** as shown at the below sample connection. The **bridge track** receives **digital current** via the **DSU**.

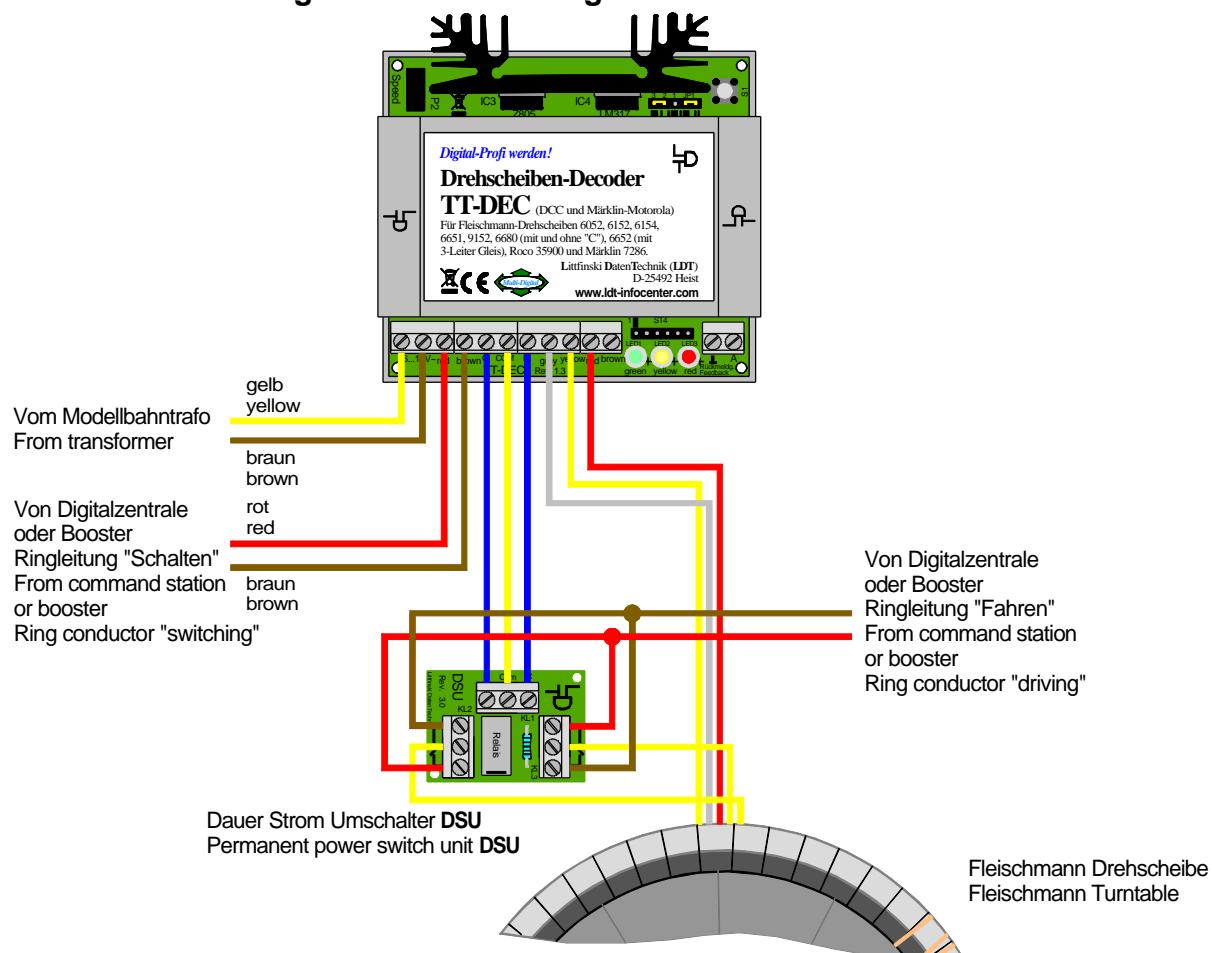

At first is it required to wire-up the **track connections** around the turntable to assure that the **opposite tracks** will have the **same polarity**. There will be a **parting line** between **two different wiring sections**. At the **lower half circle (straight line)** will be the **brown cable** always connected to the **first rail** looking at the **wiring in clockwise direction**.

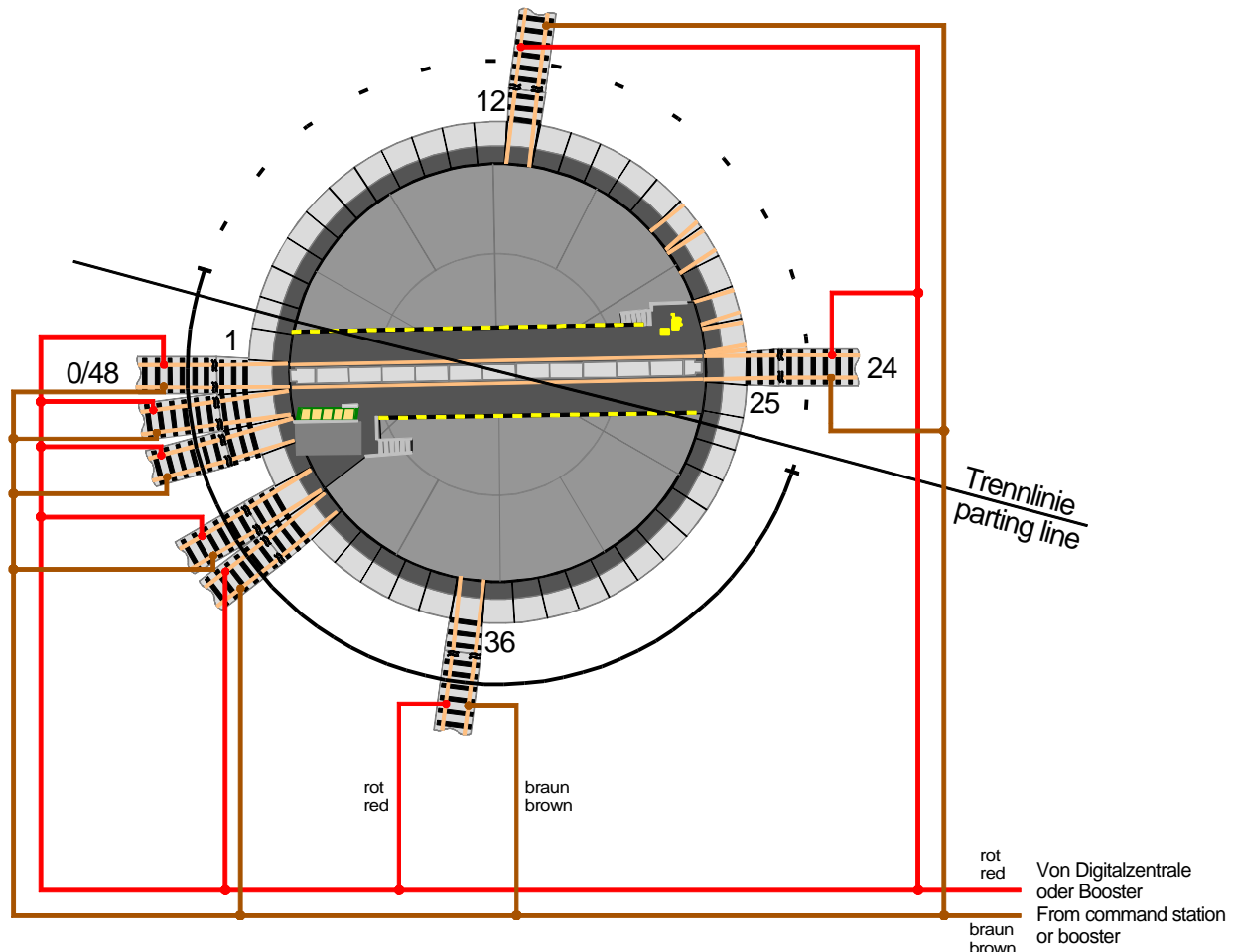

At the **upper half circle (dotted line)** will be always the **red digital cable** connected to the **first rail**, looking at the **wiring in clockwise direction**.

If the turntable bridge is passing the **parting line** between the two wiring sections is a **change of the polarity** of the **bridge track** required because the turntable bridge rails get digital current supply as well. This can be done by the **TurnTable-Decoder TT-DEC** via the permanent power switch unit **DSU** if it knows the **parting line**.

### Programming sequence:

1. **Press** shortly **2-times** the **key S1**. Now the **green LED** will **flash**.
2. **Turn** the turntable bridge with the **command >Step<** **clockwise** to the **track segment** with the imaginary **parting line**. The **position** of the **turntable bridge** shown at the **PC screen** or on the **display** does not matter provided that the adjustments will be carried out via your **model railway software** or via your **command station** with **turntable indication**.



3. Send the command **>Drehrichtung<** (turning direction) **clockwise** or **anti clockwise**. The **position of changing the polarity** will be **stored** and the **programming mode** will be **closed**. The **turntable bridge** will **turn automatically** to the **track connection 1**.
4. **Control:** Send the command **>Turn<**. If the **turntable bridge** is **passing the parting line** the **red LED** will **shortly switch off**. If already a **permanent power switch unit (DSU)** for the **change of polarity** of the **bridge track** has been installed to the TT-DEC the **relay of the DSU relay** will give a **click**.

## 4.5. Synchronizing the reference track:

If the **indication** of the **turntable bridge position** of the **model railway software** or on the **display** of the **command station** does not conform to the real position of the **turntable bridge** is it possible to carry out a **synchronization process**.

### Synchronization process:

1. Press **shortly 1 time** the key **S1**. The **yellow LED** will **flash**.
2. Turn the **turntable bridge** with the commands **>Step<** (**clockwise** or **anti clockwise**) to the **track 1 (reference track)**. The position of the turntable indicated on the PC screen or on the display does not matter.
3. Send the **command: turn directly to track 1**. The **turntable bridge does not turn**. The **turntable symbol** on the screen or on the display indicates now **also track 1**. If the **position of the control housing** is **not correct** please **send again** the command **turn directly to track 1**.
4. Send now the command **>Drehrichtung<** (**turn direction**) **clockwise** or **anti clockwise**. The **synchronization process** is **now completed** and the **yellow LED** will be **switched off**.

## 4.6. Special function: Turntable test / Factory setting:

### 4.6.1. Turntable test:

Press the **programming key S1 approx. 4 seconds** until the **red LED** will **switch off**. The **bridge** will turn by **360 degree** after **releasing the key** and will **stop shortly** on each **programmed track connection**.

### 4.6.2. Factory setting:

If the **programming-key S1** will be **depressed** for 2 seconds during **switching-on** the TT-DEC, all **adjustments** will be **deleted** and the **factory setting** will be **restored** (**basic address 225, data format DCC, all 24** respectively **48 track connections** are **programmed** in accordance to the adjusted type of turntable re. chapter 2).



**4.7. Programming- and Control-table:**

turntable function (command) operation mode	programming mode	area: 14 address	area: 15 address	turnout command	key	Symbol CS 2	Symbol CS 1 / ECoS	Symbol Win-Digipet	Symbol TrainController
-	> Ende <	209	225	round	red / -	End	End	End	not available
-	> Input <	209	225	straight	green / +	Input	Input	Input	not available
-	> Clear <	210	226	round	red / -	clear	Clr	Clear	
> Turn <	> Turn <	210	226	straight	green / +	turn	180°	Turn	not available
clock wise	clock wise	211	227	round	red / -	step	step	Step	
> Step <	> Step <	211	227	straight	green / +	step	step	Step	
anti clock wise	anti clock wise	212	228	round	red / -	Δ	DIR		
> Drehrichtung <	> Drehrichtung <	212	228	straight	green / +	∇	DIR		
anti clock wise	anti clock wise	213	229	round	red / -	1			
track connection 1	-	213	229	straight	green / +	2			
track connection 2	-	214	230	round	red / -	3			
track connection 3	-	214	230	straight	green / +	4			
track connection 4	-	...	...	...	...	...	...	...	...
...	...	...	...	...	...	...	...	...	...
track connection 23	-	224	240	round	red / -	23			
track connection 24	-	224	240	straight	green / +	24			

# TT-DEC – Manual

## 5. Feedback reports:

The Turntable-Decoder TT-DEC is able to **send** the information “**position reached**” and “**bridge track occupied**” to the **feedback modules**. Those **feedback information** can be **used** by a **digital command station** or a **model railway software** for further **automatic control operation** of the turntable.

After the **turntable bridge reaches** the wanted **position** the **TurnTable-Decoder TT-DEC** creates a **feedback signal** on the **2-poles clamp KL5** marked with “**feedback**” for the **evaluation** of the **model railway software**.

The information “**bridge track occupied**” will be realized by the **3-conductor rail** via a **contact rail (one isolated bridge rail)** and by the **2-conductor rail** via a **track occupancy report** by use of **current measurement**.

With reference to the installed **turntable** and **digital system** there will be **different feedback modules** used for the two feedback information “**position reached**” and “**bridge track occupied**”.

The (**colored**) **wiring samples** on the **following pages** and **further samples** for the thematic **feedback** can be found as well on our **Web-site** at the **section “sample connections”** for the **Turntable-Decoder TT-DEC**.

### 5.1. Feedback Reports with the Märklin turntable (3-conductor rails):

#### 5.1.1. Position reached and bridge track occupied with standard Feedback Module RM-88-N for the s88-Feedback bus:

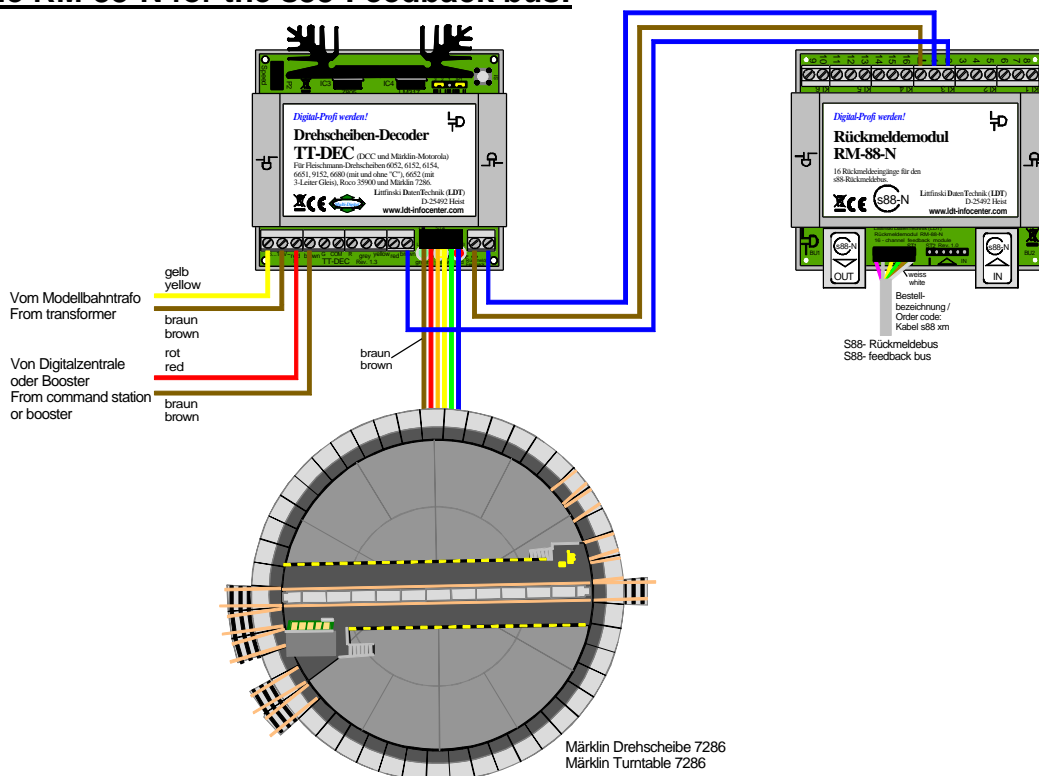

Position reached and bridge track occupied with RM-88-N



# TT-DEC – Manual

## 5.1.2. Position reached and bridge track occupied with Optocoupling-Feedback Module RM-88-N-O for the s88-Feedback bus:

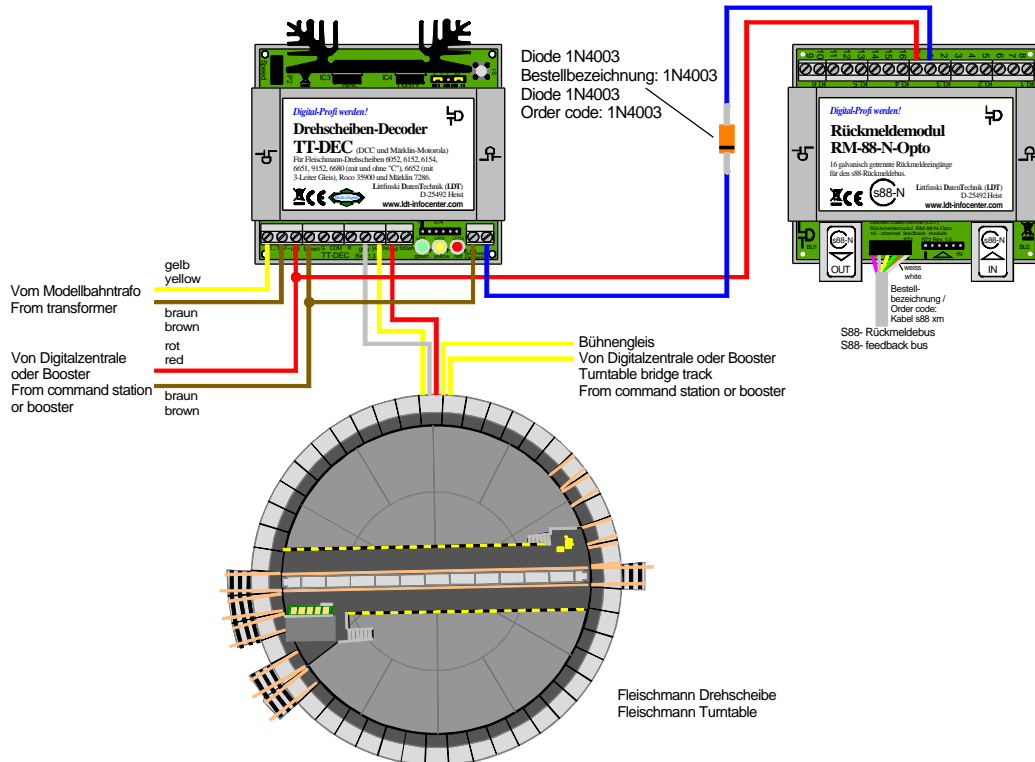

Position reached and bridge track occupied with RM-88-N-O

## 5.2. Feedback reports with Fleischmann turntables and Roco turntable 35900 (2-conductor rails):

### 5.2.1. Position reached and bridge track occupied with RM-GB-8-N for the s88-Feedback bus:

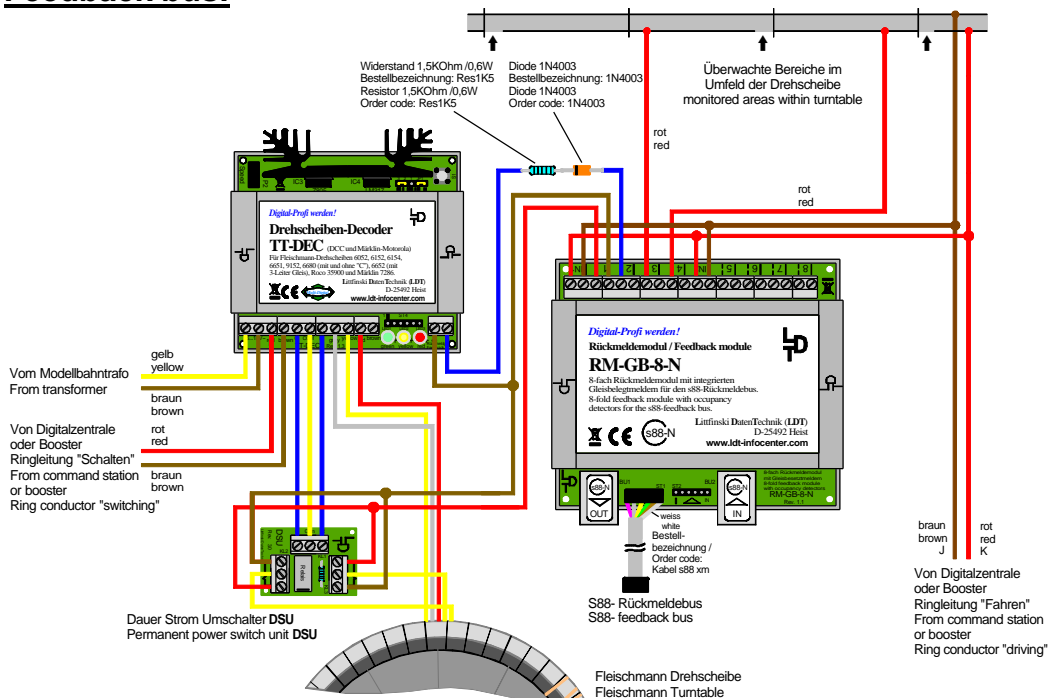

Position reached and turntable bridge occupied with RM-GB-8-N

# TT-DEC – Manual

## 5.2.2 Position reached and bridge rail occupied with RS-8 for the RS-Feedback bus:

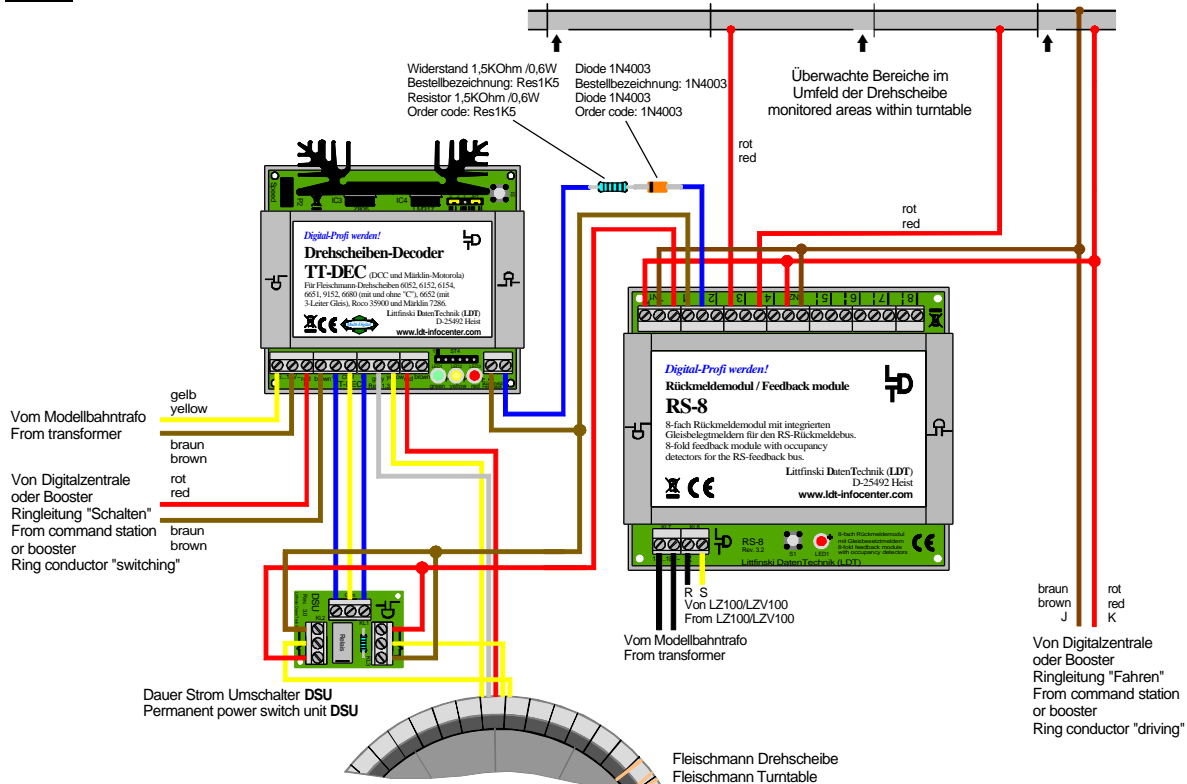

Position reached and bridge rail occupied with RS-8

## 5.2.3. Position reached and bridge rail occupied with GBM-8 and Roco Feedback Module 10787 for the Roco Feedback bus:

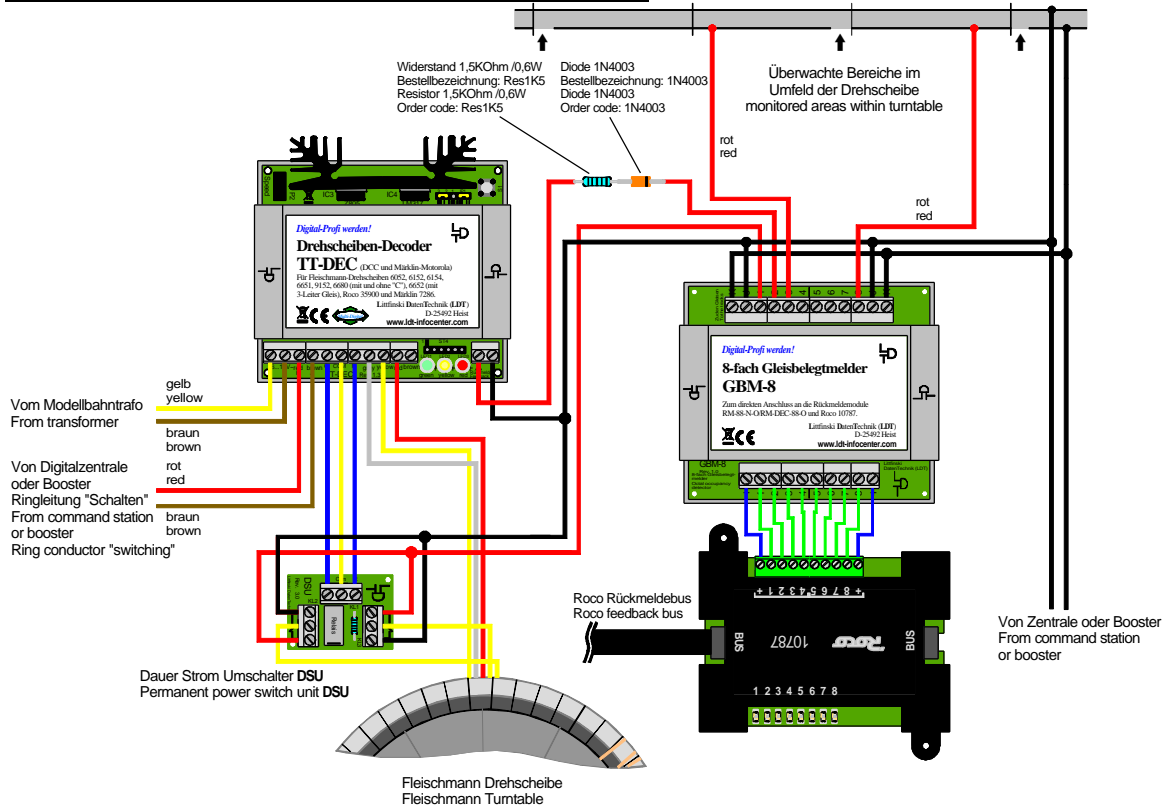

Position reached and bridge rail occupied with GBM-8

# TT-DEC – Manual

## 5.2.4. Position reached and bridge rail occupied with Uhlenbrock 63 340 for the LocoNet:

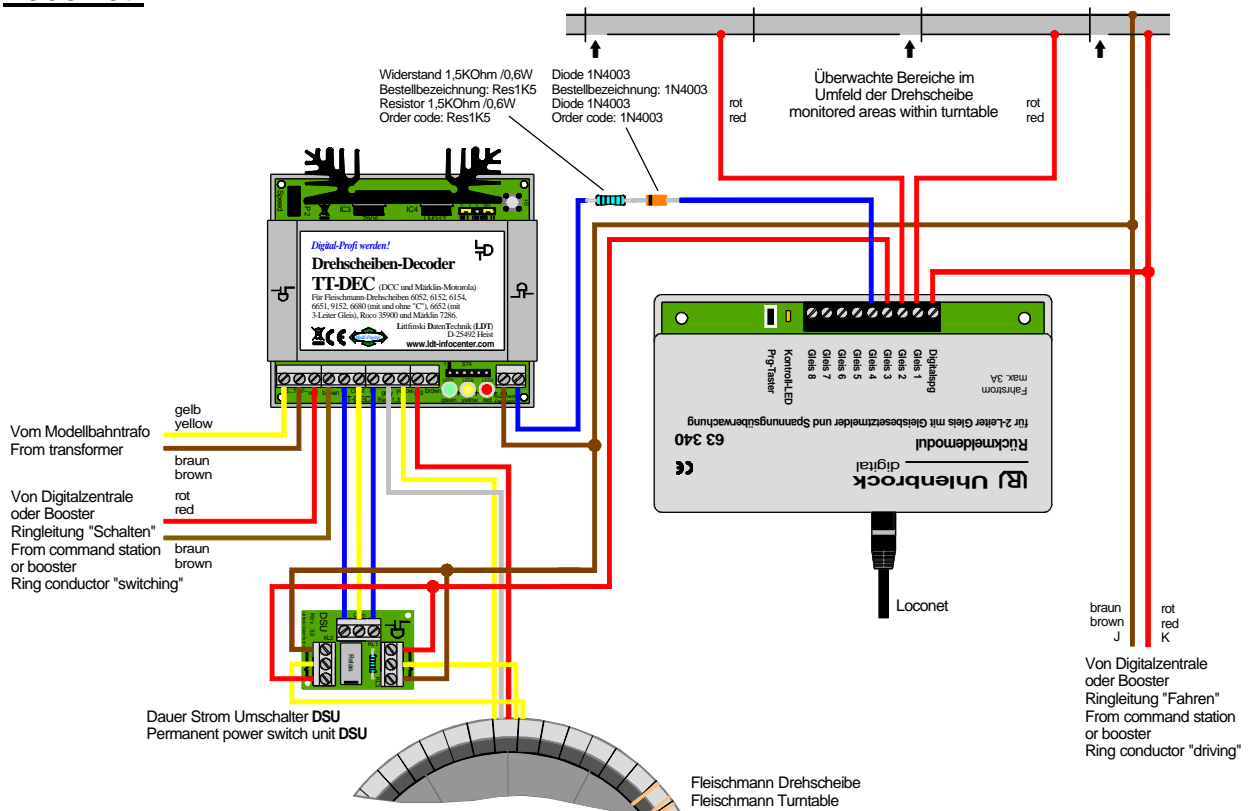

Position reached and bridge rail occupied with Uhlenbrock 63 340 for the LocoNet.

**6. Assembly plan:**

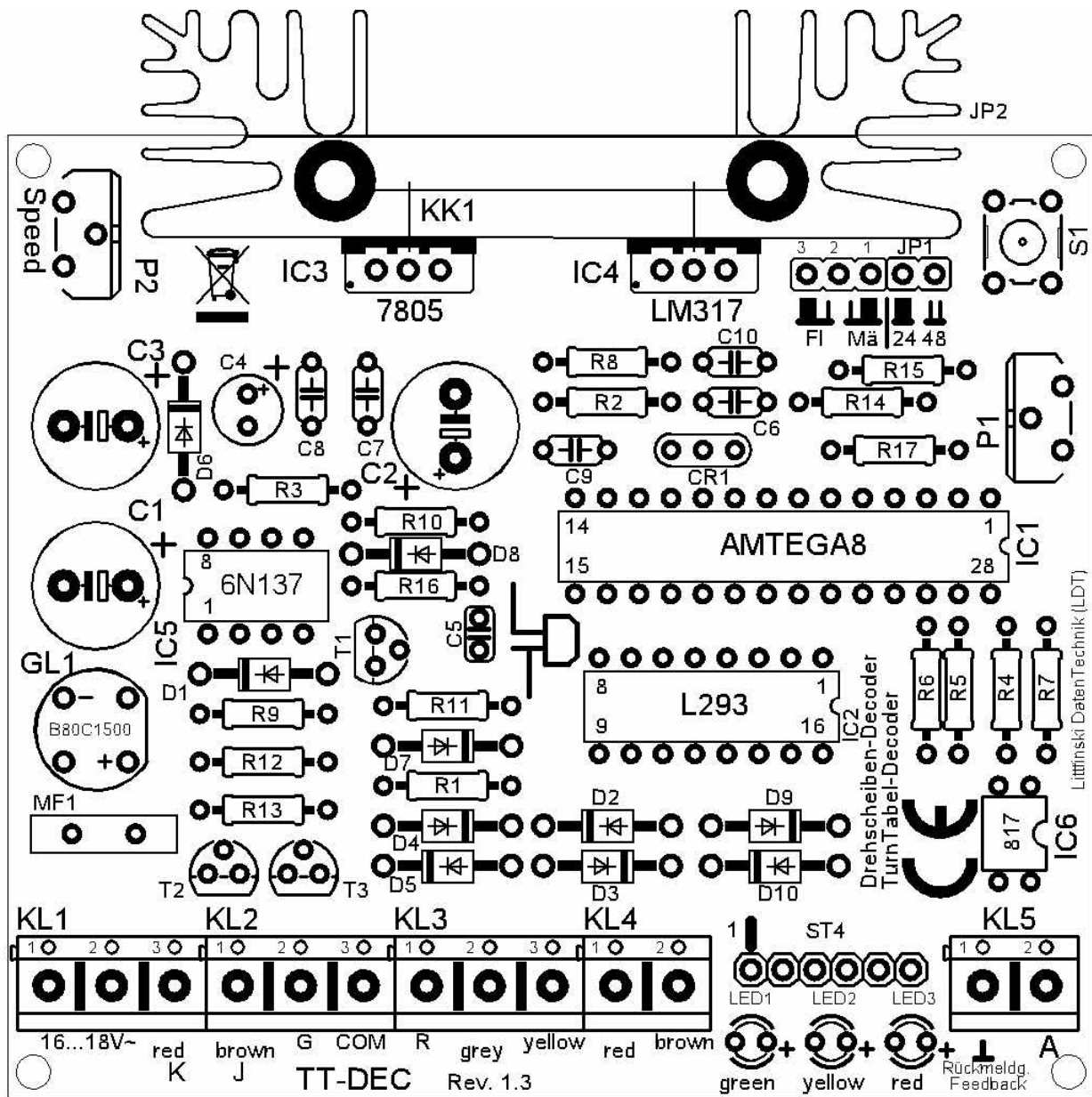

Made in Europe by  
**Littfinski DatenTechnik (LDT)**  
 Kleiner Ring 9  
 D-25492 Heist/Germany  
 Phone: 0049 4122 / 977 381  
 Fax: 0049 4122 / 977 382  
 Internet: <http://www.ldt-infocenter.com>

Subject to technical changes and errors. © 03/2016 by LDT  
 Märklin and Motorola and Fleischmann are registered trademarks.